



BOSCH

Invented for life



Kliklok Celox

Endload Cartoner High Speed, High Performance

The Kliklok Celox is ideally suited for frozen and refrigerated/prepared foods. It has the flexibility to rapidly adapt to changing production needs, operates at high efficiency with very low down-time, and reduces maintenance and running costs.

The high performance Celox can be integrated with Kliklok's product handling systems to package a variety of products like frozen entrees, appetizers, flow wrapped pancakes, muffins, cupcakes, crackers, pizzas, and biscuits.

Outstanding access for changeovers and maintenance

The Celox's carton feeder and inserter module are on the same side of the machine, creating convenient access to the heart of the machine, all from one side.

Easy operation with Insight® color touchscreen HMI

The industry-leading Insight® color graphic touchscreen HMI is intuitive and features recipe-based programming that reduces operator error and ensures consistent performance regardless of shift or operator skill. Enhanced diagnostics are standard.

Fastest rotary carton feeder in the industry

Kliklok's patented rotary carton feeder is the fastest, most positive in the industry. The straight-pick motion reduces wear on suction cups and short, rigid bars minimize deflection. The servo motion profile erects cartons in the direction of product flow with a 30% greater carton-open time.

Hybrid modular stainless steel frame

The fully-welded stainless steel frame is a hybrid construction of tubular steel and formed plates, creating a torsionally rigid, vibration-free platform. The modular design allows for custom configuration with standard assemblies, reducing build time and costs.

Rapid changeovers with semi-automatic adjustments

Recipe-based programming and extensive use of servo motors provides fast semi-automatic machine setup and adjustment. The quick-change carton gate, feeder bars, and simple hand wheels with Siko counters reduce changeovers to a few minutes.

Key Features

- ▶ Speeds up to 325 cpm (9" pitch)
- ▶ Fastest rotary carton feeder in the industry
- ▶ Easy-to-use Insight® touchscreen HMI
- ▶ Sanitary stainless steel design (IP65)
- ▶ 2-D servo-driven semi-automatic size adjustment
- ▶ OMAC PackML compliant
- ▶ Ethernet network connectivity

Packaging System Structure

Primary Packaging

Product Handling

Secondary Packaging

Kliklok Celox Endload Cartoner

Technical Specifications

Performance		Carton Size Range	Minimum	Maximum
Production Speed	Variable to 325 cpm (9" pitch)	Length (9" pitch)	80 mm (3.14")	203 mm (8.00")
Actual speed depends upon machine configuration and carton size and style.	Variable to 250 cpm (12" pitch)	Length (12" pitch)	80 mm (3.14")	279 mm (11.00")
	Variable to 200 cpm (15" pitch)	Length (15" pitch)	80 mm (3.14")	355 mm (14.00")
Operating Requirements		Width	25 mm (1.00")	100 mm (3.94")
Power Consumption	28 kVA	Depth	110 mm (4.33")	305 mm (12.00")
Air	283 liters/min (10 cfm)	An individual carton combining multiple minimum or maximum dimensions may not be compatible with the standard system.		
	5.5 bar (80 psi)			
Construction				
Fully-welded tubular stainless steel frame. Stainless steel shafts. Nickel-plated chains, pulleys and sprockets. Polycarbonate overhead guards.				
Shipping Weight	4536 kg (10,000 lb)			

Standard Features

- ▶ Heavy-duty, fully-welded, stainless steel, angled-surface washdown frame (IP65 standards)
- ▶ 1430 mm (56.29") hopper capacity
- ▶ Independently-servo-driven flight chains
- ▶ Patented servo-driven rotary carton feeder
- ▶ Barrel-cam product inserter
- ▶ Product reclaim conveyor
- ▶ Ancillary device mounting rails
- ▶ Digital Proportional Glue Regulator
- ▶ Semi-automatic carton size adjustment
- ▶ Corrosion-resistant nickel-plated chains
- ▶ Insight® icon-based color graphic touch screen operator interface
- ▶ Allen-Bradley CompactLogix™ control system
- ▶ Sanitary washdown wiring
- ▶ Low level carton indicator
- ▶ Status beacon
- ▶ OMAC PackML compliant
- ▶ Powered carton hopper
- ▶ Ethernet network connectivity

Optional Features

- ▶ Alternative flight pitch
- ▶ 5-crease sleeve capability
- ▶ 3D servo size change
- ▶ Enhanced diagnostics and on board manuals
- ▶ Alternative closing means (tuck, gable, etc.)
- ▶ Opposite hand configuration
- ▶ Low level hopper
- ▶ Integrated open carton flap detect/reject

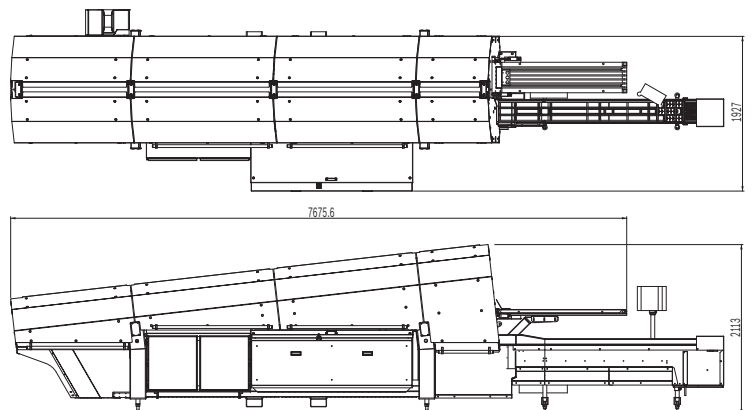

Bosch Packaging Technology

boschpackaging.com

Kliklok-Woodman 5224 Snapfinger Woods Drive, Decatur, GA 30035
USA +1 770-981-5200 kliklokwoodman.com

Kliklok International Western Drive, Hengrove Park Estate,
Bristol, BS14 0AY UK +44 1275 836131 kliklok-int.com